

UVC6DF2T

8MP WDR Fixed Dome Camera



Key Features:

- 8MP WDR Fixed Dome Camera
- WDR, 2D/3D DNR
- 2.8mm, 3.6mm Fixed lens
- 98ft(30m) IR distance
- Water and dust resistant (IP67)
- 4 in 1 (4 signals switchable TVI/AHD/CVI/CVBS)

■ Specifications

Camera	
Image Sensor	1/2.8" CMOS Sensor
Signal System	PAL/NTSC
Effective Pixels	3840 (H) ×2160 (V)
Electronic Shutter	AUTO/ 1/50(1/60) -1/50,000sec
Min. Illumination	0.01 Lux@(F1.2, AGC ON), 0 Lux with IR
Video Frame Rate	PAL/NTSC: 8MP@15fps
Video Output	AHD / TVI / CVI / CVBS
Camera Features	
S/N Ratio	≥50dB
Noise Reduction	2D/3D DNR
Day & Night	EXT/Auto/Color/B&W
White Balance	ATW
WDR	WDR
IR LED	3pcs Array LED
IR Range	98ft(30m)
Lens	
Focal Length	2.8mm/3.6mm Fixed Lens
Angle of View	2.8mm: Horizontal FOV: 109°, Vertical FOV: 63°, Diagonal FOV: 125° 3.6mm: Horizontal FOV: 92°, Vertical FOV: 51°, Diagonal FOV: 105°
Lens Type	Fixed Iris
Mount Type	M12
General	
IP Rating	IP67

Vandal Proof	N/A
Housing Material	Metal
Power Supply	DC12V (±10%)
Power Consumption	<12W
Working Temperature / Humidity	-40°F ~ 140°F (-40°C ~ 60°C) Humidity 95% or less (non-condensing)
Dimensions(W×D×H)	Φ4.49" × 3.53" (114 × 89.6 mm)
Weight	480g

■ Available Model

UVC6DF2T (2.8mm)

UVC6DF2T (3.6mm)

■ Dimensions

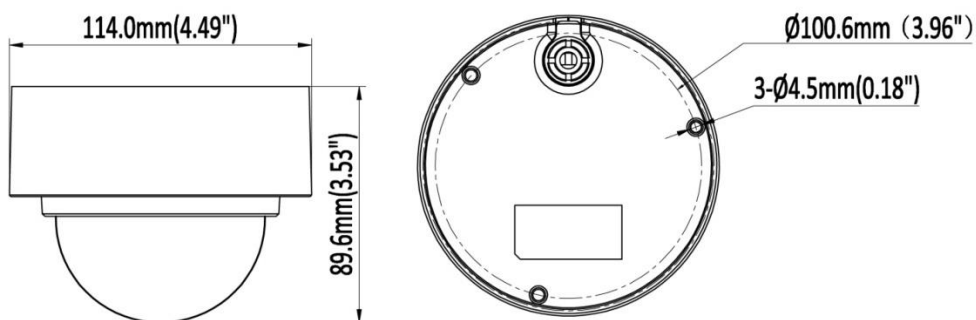

■ Related Accessories

Junction Box, Φ112.5*49.5mm, AC-JB02	Junction Box, Φ112.5x41 mm, LB11	Junction Box, 120x105.8x183.5mm, AC-WM02
		

©Homaxi Inc. All rights reserved.

*Product specifications are subject to change without notice.